



COMPONENTES



SurTécnica
SISTEMAS TRANSPORTADORES

TRACCIÓN- TRACTION

Piñón Z19 Cadena Recta Inox. Tipo 815-812

Sprockets Z19 Straight Stainless Chain Type 815-812

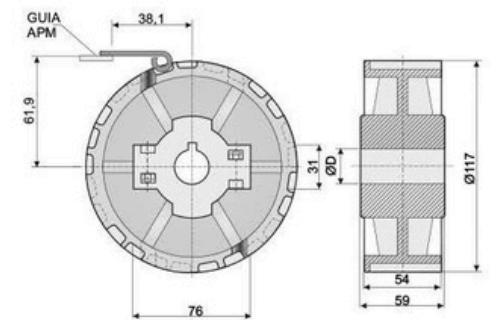
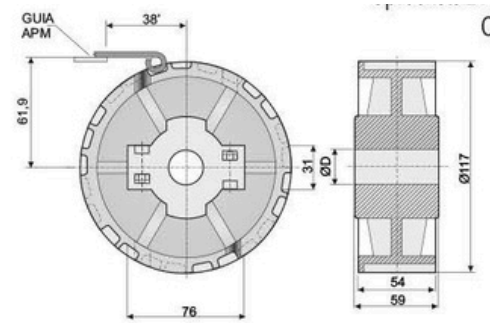

PIEZA	DESCRIP.	PESO	VENTA	COLOR	MATERIALES	Ø D
1036	PIÑÓN Z19 SIN	501g	Unidad	NEGRO	PIÑÓN=PAFG TORNILLO=AISI 304 TUERCA= NPB	25
1037	CHAVETERO	487g				30
1038	PIÑÓN Z19 CON	472g				35
1048	CHAVETERO	496g				25
1049	PIÑÓN Z19 SIN	482g				30
1050	CHAVETERO	467g	35			

PIñón Z19 Cadena Recta Acetal Tipo 820-831

Sprockets Z19 Straight Acetal Chain Type 820-831

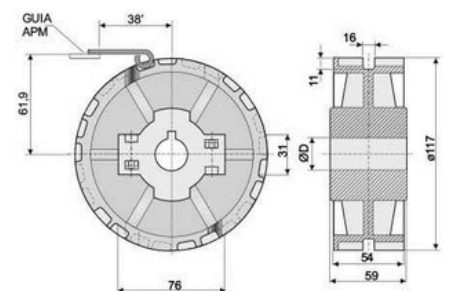
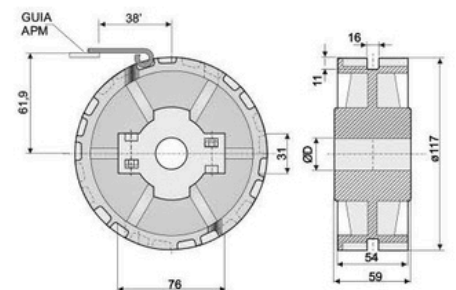

PIEZA	DESCRIP.	PESO	VENTA	COLOR	MATERIALES	Ø D
1044	PIÑÓN Z19 SIN CHAVETERO	450g	Unidad	NEGRO	PIÑÓN=PAFG TORNILLO=AISI 304 TUERCA= NPB	25
1045		436g				30
1046		420g				35
1056		445g				25
1057		431g				30
1058		415g				35

TRACCIÓN- TRACTION

Piñón Z19 Cadena Curva Inox. Tipo 881

Sprockets Z19 Curve Stainless Chain Type 881

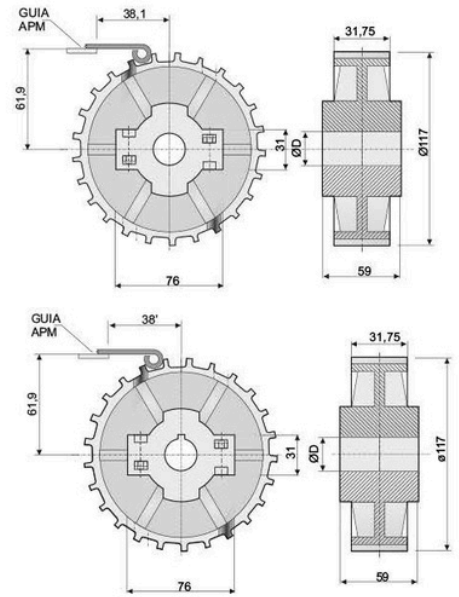

PIEZ A	DESCRIP.	PESO	VENTA	COLOR	MATERIALES	Ø D
1040	PIÑON Z19	401g	Unidad	NEGRO	PIÑON=PAFG TORNILLO=AISI 304 TUERCA= NPB	25
1041	SIN	387g				30
1042	CHAVETERO	372g				35
1052	PIÑON Z19	396g				25
1053	CON	382g				30
1054	CHAVETERO	368g	35			

EJEMPLO DE APLICACION:

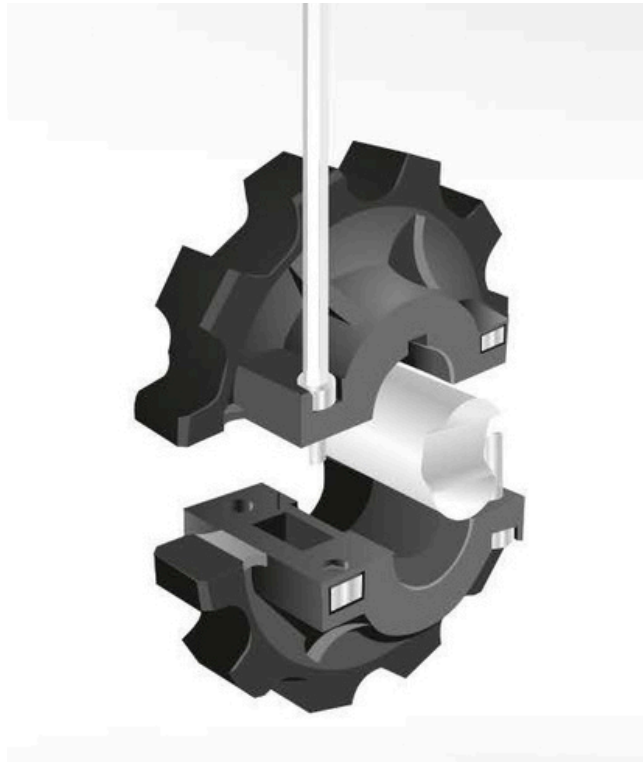

TRACCIÓN- TRACTION

Piñón Z21 Cadena Recta Inox. Tipo 815-812

Sprockets Z19 Straight Stainless Chain Type 815-812

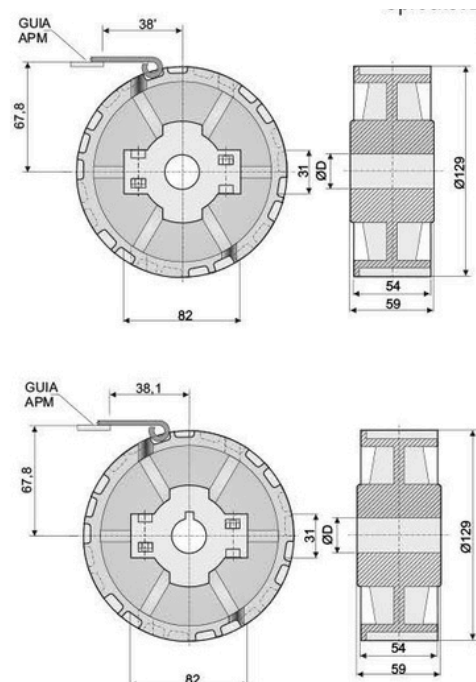

PIEZ A	DESCRIP.	PESO	VENTA	COLOR	MATERIALES	Ø D
454	PIÑÓN Z21 SIN CHAVETERO PIÑÓN Z21 CON CHAVETERO	488g	Unidad	NEGRO	PIÑÓN=PAFG TORNILLO=AISI 304 TUERCA= NPB	25
455		484g				30
456		481g				35
457		478g				40
466		488g				25
467		484g				30
468		481g				35
469		478g				40

EJEMPLO DE APLICACION:



TRACCIÓN- TRACTION

Piñón Z21 Cadena Recta Acetal Tipo 820-831

Sprockets Z21 Straight Acetal Chain
Type 820-831 With Keyway

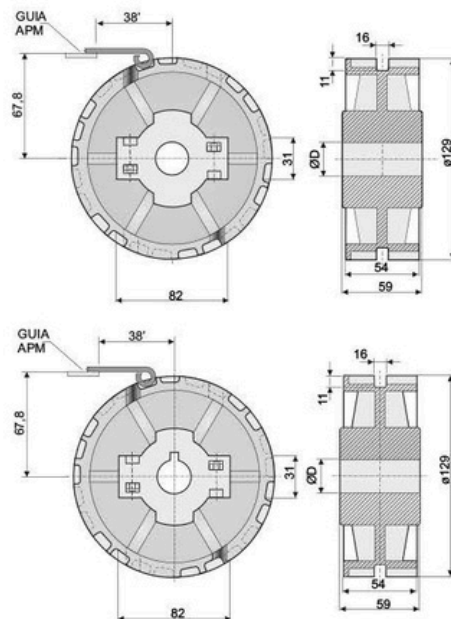

PIEZA	DESCRIP.	PESO	VENTA	COLOR	MATERIALES	Ø D
462	PIÑON Z21 SIN CHAVETERO PIÑON Z21 CON CHAVETERO	465g	Unidad	NEGRO	PIÑON=PAFG TORNILLO=AISI 304 TUERCA= NPB	25
463		462g				30
464		458g				35
465		454g				40
474		465g				25
475		462g				30
476		458g				35
477	454g	40				

Piñón Z21 Cadena Curva Inox. Tipo 881

Sprockets Z21 Curve Stainless
Chain Type 881

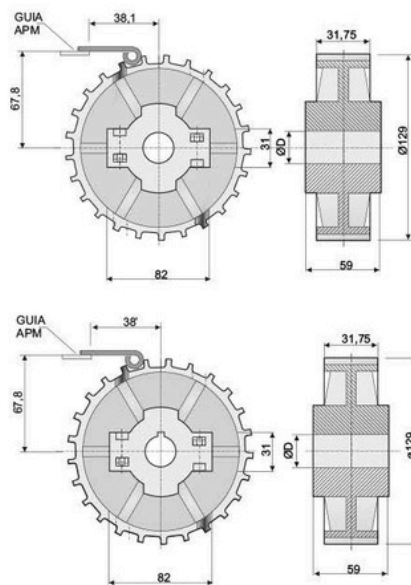

PIEZA	DESCRIP.	PESO	VENTA	COLOR	MATERIALES	Ø D
458	PIÑON Z21 SIN CHAVETERO PIÑON Z21 CON CHAVETERO	445g	Unidad	NEGRO	PIÑON=PAFG TORNILLO=AISI 304 TUERCA= NPB	25
459		441g				30
460		437g				35
470		434g				40
471		488g				25
472		484g				30
473		481g				35
		478g				40

TRACCIÓN- TRACTION

Piñón Z23 Cadena Recta Inox.Tipo 815-812

Sprockets Z23 Straight Stainless Chain Type 815-812

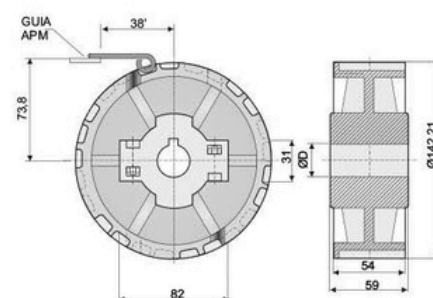
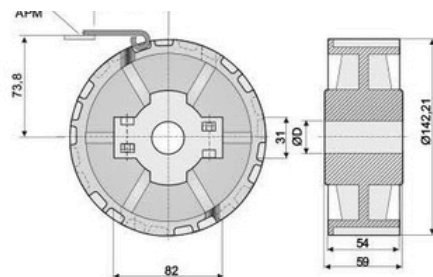

PIEZA	DESCRIP.	PESO	VENTA	COLOR	MATERIALES	Ø D
478	PIÑÓN Z23 SIN CHAVETERO PIÑÓN Z23 CON CHAVETERO	594g	Unidad	NEGRO	PIÑÓN=PAFG TORNILLO=AISI 304 TUERCA= NPB	25
479		591g				30
480		587g				35
481		584g				40
490		484g				25
491		581g				30
492		577g				35
493	574g	40				

Piñón Z23 Cadena Recta Acetal Tipo 820-831

Sprockets Z23 Straight Acetal Chain Type 820-831

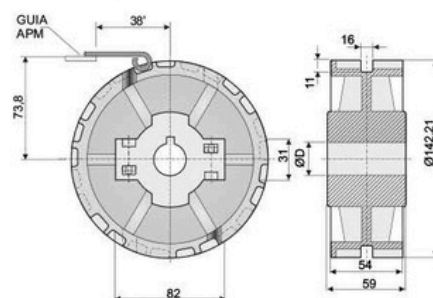
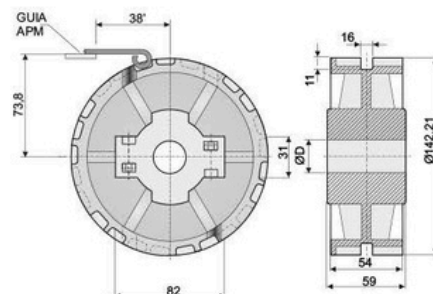

PIEZA	DESCRIP.	PESO	VENTA	COLOR	MATERIALES	Ø D
486	PIÑÓN Z21 SIN CHAVETERO PIÑÓN Z21 CON CHAVETERO	465g	Unidad	NEGRO	PIÑÓN=PAFG TORNILLO=AISI 304 TUERCA= NPB	25
487		462g				30
488		458g				35
489		454g				40
498		575g				25
499		571g				30
500		567g				35
501		563g				40

TRACCIÓN- TRACTION

Piñón Z23 Cadena Curva Tipo 881

Sprockets Z23 Curve Stainless
Chain Type 881

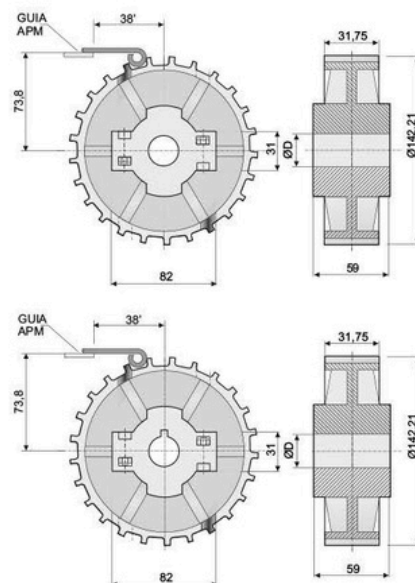

PIEZA	DESCRIP.	PESO	VENTA	COLOR	MATERIALES	Ø D
482	PIÑÓN Z23 SIN CHAVETERO PIÑÓN Z23 CON CHAVETERO	538g	Unidad	NEGRO	PIÑÓN=PAFG TORNILLO=AISI 304 TUERCA= NPB	25
483		534g				30
484		531g				35
485		528g				40
494		438g				25
495		434g				30
496		431g				35
497	428g	40				

Piñón Z25 Cadena Recta Inox. Tipo 815-812

Sprocket Z25 Straight Stainless
Chain Type 815-812

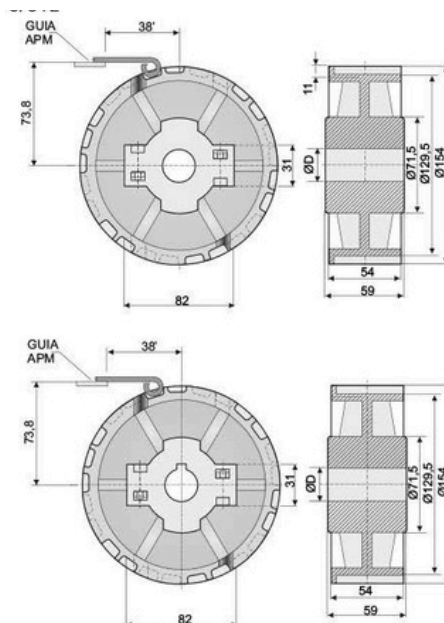

PIEZA	DESCRIP.	PESO	VENTA	COLOR	MATERIALES	Ø D
333	PIÑÓN Z25 SIN CHAVETERO PIÑÓN Z25 CON CHAVETERO	628g	Unidad	NEGRO	PIÑÓN=PAFG TORNILLO=AISI 304 TUERCA= NPB	25
099		623g				30
101		518g				35
103		615g				40
334		615g				45
331		625g				25
098		620g				30
100		515g				35
102		610g				40
332		605g				45

TRACCIÓN- TRACTION

Piñón Z25 Cadena Recta Acetal

Tipo 820-831

Sprockets Z25 Straight Acetal Chain
Type 820-831

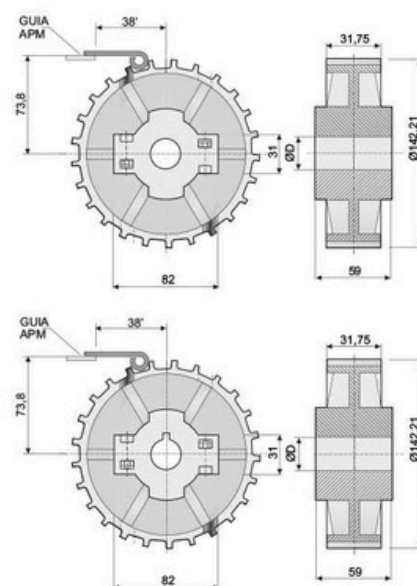

PIEZA	DESCRIP.	PESO	VENTA	COLOR	MATERIALES	Ø D
350	PIÑÓN Z25 SIN CHAVETERO PIÑÓN Z25 CON CHAVETERO	516g	Unidad	NEGRO	PIÑÓN=PAFG TORNILLO=AISI 304 TUERCA= NPB	25
351		512g				30
352		509g				35
353		506g				40
354		508g				45
345		489g				25
346		512g				30
347		508g				35
348		505g				40
349		505g				45

Piñón Z25 Cadena Curva Tipo 881

Sprockets Z25 Curve Srainless
Chain Type 881

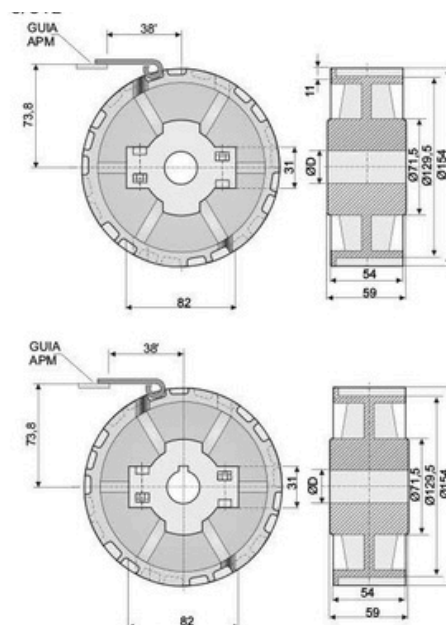

PIEZA	DESCRIP.	PESO	VENTA	COLOR	MATERIALES	Ø D
335	PIÑÓN Z25 SIN CHAVETERO PIÑÓN Z25 CON CHAVETERO	493g	Unidad	NEGRO	PIÑÓN=PAFG TORNILLO=AISI 304 TUERCA= NPB	25
336		490g				30
337		487g				35
338		484g				40
339		487g				45
340		493g				25
341		490g				30
342		487g				35
343		484g				40
344		487g				45

TRACCIÓN- TRACTION

Piñon Z33 Cadena Recta Inox.
Sprocket Z33 Straight Stainless
Chain

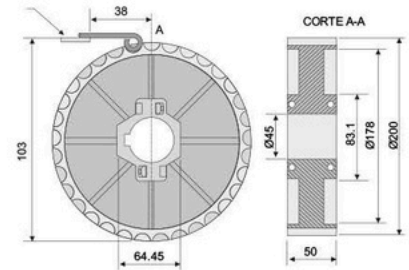

PIEZA	DESCRIP.	PESO	VENTA	COLOR	MATERIALES	Ø D
1844	PIÑON Z33 CON CHAVETERO	718g	Unidad	NEGRO	PIÑON=PAFG TORNILLO=AISI 304 TUERCA= NPB	45

Piñon Z17 Bipa. Vert. Cad. Rec. Acetal Tipo 820-831
Sprockets Z17 Vert. Bip. Straight
Acetal Chain Type 820-831

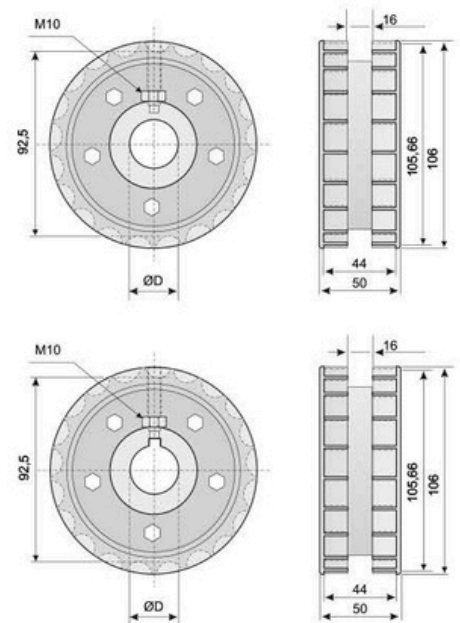

PIEZA	DESCRIP.	PESO	VENTA	COLOR	MATERIALES	Ø D
1160 1161 1162 1163 1164 1165	PIÑON Z17 SIN CHAVETERO PIÑON Z17 CON CHAVETERO	369g	Unidad	NEGRO	PIÑON=PAFG TORNILLO=AISI 304 TUERCA= NPB	25 30 35 25 30 35

TRACCIÓN- TRACTION

Piñón Z19 Bipa. Vert. Cadena Acetal Tipo 820-831

Sprocket Z19 Vert. Bipa. Acetal Chain Type 820-831

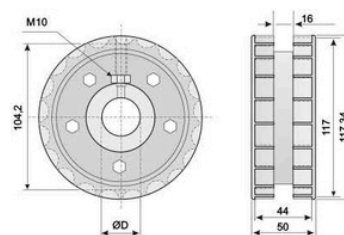
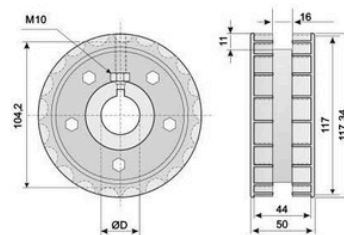

PIEZA	DESCRIP.	PESO	VENTA	COLOR	MATERIALES	Ø D
700	PIÑÓN Z19 SIN CHAVETERO PIÑÓN Z19 CON CHAVATERO	345g	Unidad	NEGRO	PIÑÓN=PAFG TORNILLO=AISI 304 TUERCA= NPB	25
701						30
702						35
703						40
704						45
715						25
716						30
717						35
718						40
719	45					

Piñón Z21 Bipa. Vert. Cadena Acetal Tipo 820-831

Sprockets Z21 Vert. Bip. Acetal Chain Type 820-831

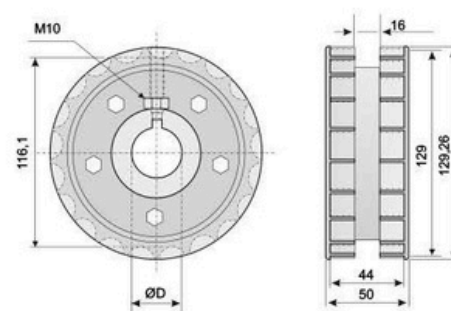
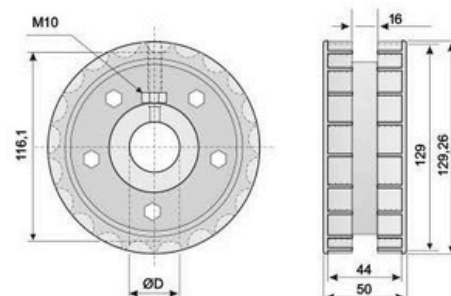

PIEZA	DESCRIP.	PESO	VENTA	COLOR	MATERIALES	Ø D
730	PIÑÓN Z21 SIN CHAVETERO PIÑÓN Z21 CON CHAVETERO	645g	Unidad	NEGRO	PIÑÓN=PAFG TORNILLO=AISI 304 TUERCA= NPB	25
731						30
732						35
733						40
734						45
745						25
746						30
747						35
748						40
749	45					

TRACCIÓN- TRACTION

Piñon Z23 Bipa. Vert. Cadena Rec. Acetal Tipo 820-831

Sprocket Z23 Vert. Bip. Straight
Acetal Chain Type 820-831

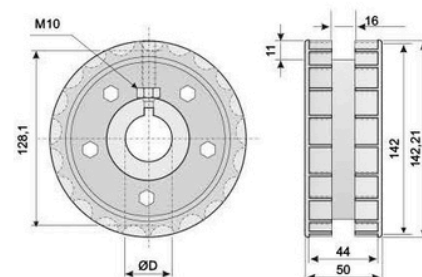
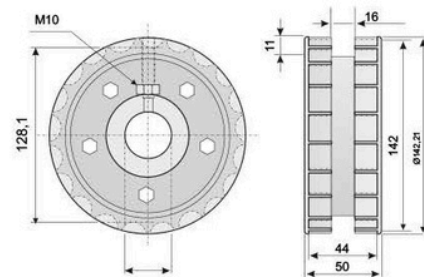

PIEZA	DESCRIP.	PESO	VENTA	COLOR	MATERIALES	Ø D
760	PIÑON Z23 SIN CHAVETERO PIÑON Z23 CON CHAVATERO	729g	Unidad	NEGRO	PIÑON=PAFG TORNILLO=AISI 304 TUERCA= NPB	25
761						30
762						35
763						40
764						45
775						25
776						30
777						35
778						40
779	45					

Piñon Z10 Cadena Curva Acetal Tipo 880

Sprockets Z10 Curve Acetal.
Chain Type 880

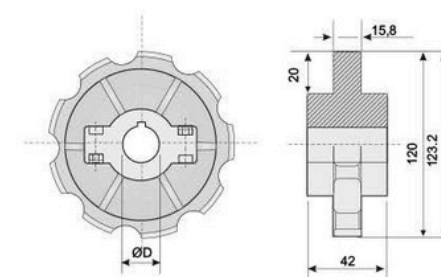
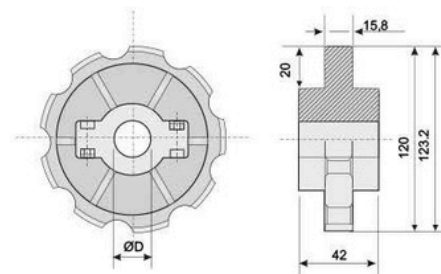

PIEZA	DESCRIP.	PESO	VENTA	COLOR	MATERIALES	Ø D
931	PIÑON Z23 SIN CHAVETERO PIÑON Z23 CON CHAVETERO	390g	Unidad	NEGRO	PIÑON=PAFG TORNILLO=AISI 304 TUERCA= NPB	25
932						30
933						35
934						40
935						25
936						30
937						35
938						40

TRACCIÓN- TRACTION

Piñón Z10 Cadena Curva Acetal Tipo 882

Sprockets Z10Curve Acetal Chain
Type 882

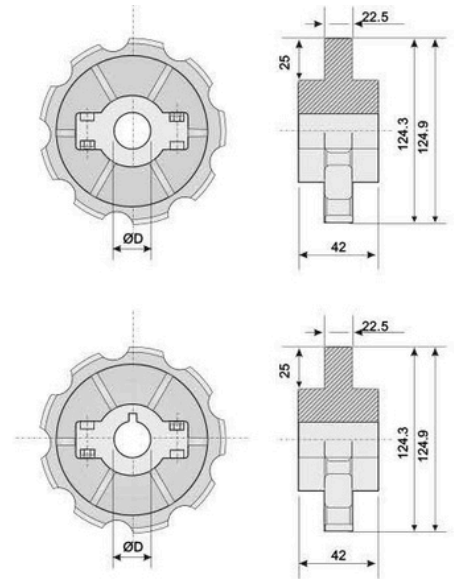

PIEZA	DESCRIP.	PESO	VENTA	COLOR	MATERIALES	Ø D
939	PIÑÓN Z10 SIN CHAVETERO PIÑÓN Z10 CON CHAVATERO	260g	Unidad	NEGRO	PIÑÓN=PAFG TORNILLO=AISI 304 TUERCA= NPB	25
940						30
941						35
942						40
943						25
944						30
945						35
946	40					

Piñón Z12 Cadena Curva Acetal Tipo 880

Sprockets Z12 Curve Acetal
Chain Type 880

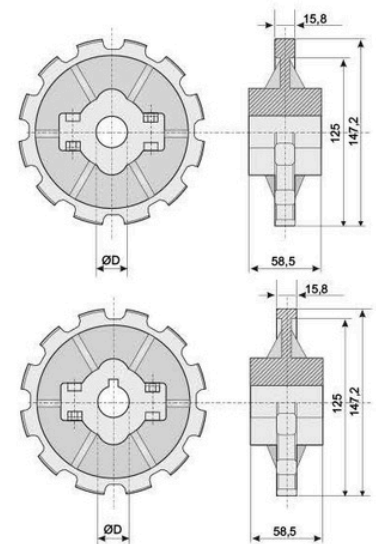

PIEZA	DESCRIP.	PESO	VENTA	COLOR	MATERIALES	Ø D
785	PIÑÓN Z12 SIN CHAVETERO PIÑÓN Z12 CON CHAVETERO	390g	Unidad	NEGRO	PIÑÓN=PAFG TORNILLO=AISI 304 TUERCA= NPB	25
786						30
787						35
789						40
790						25
791						30
792						35
	40					

TRACCIÓN- TRACTION

Piñón Z12 Para Cadena Tipo 882 Sprockets Z12 Chain Type 882

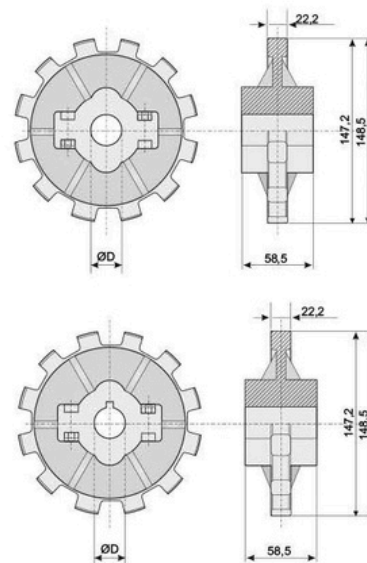

PIEZ A	DESCRIP.	PESO	VENTA	COLOR	MATERIALES	Ø D
793	PIÑON Z12 SIN CHAVETERO PIÑON Z12 CON CHAVETERO	390g	Unidad	NEGRO	PIÑON=PAFG TORNILLO=AISI 304 TUERCA= NPB	25
794						30
794						35
796						40
797						25
798						30
799						35
800						40

TRACCIÓN- TRACTION

Roldana de Retorno Bipartida Z19

Idler Wheels Z19

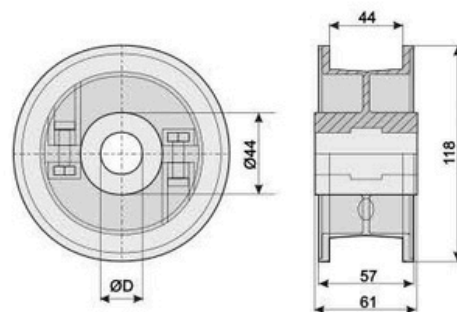

PIEZA	DESCRIP.	PESO	VENTA	COLOR	MATERIALES	Ø D
858	ROLDANA BIPARTIDA Z19	339g	Unidad	GRIS	ROLDANA=PA DISULFURO=(MO) TORNILLO=AISI 304	25
859		334g				30
860		330g				35
						40
						25
						30
						35
						40

Roldana de Retorno Bipartida Z21

Idler Wheels Z21

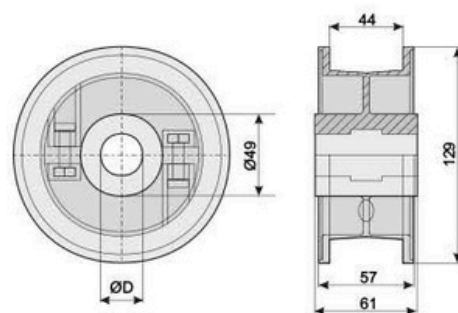

PIEZA	DESCRIP.	PESO	VENTA	COLOR	MATERIALES	Ø D
502	ROLDANA BIPARTIDA Z21	339g	Unidad	GRIS	ROLDANA=PA DISULFURO=(MO) TORNILLO=AISI 304	25
503		334g				30
504		330g				35
505		327g				40

TRACCIÓN- TRACTION

Roldana de Retorno Bipartida Z23

Idler Wheels Z23

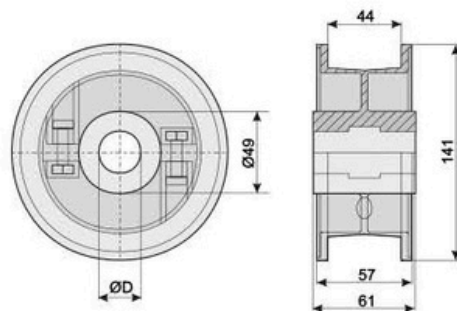

PIEZA	DESCRIP.	PESO	VENTA	COLOR	MATERIALES	Ø D
506	ROLDANA BIPARTIDA Z23	364g	Unidad	GRIS	ROLDANA=PA DISULFURO=(MO) TORNILLO=AISI 304	25
507		360g				30
508		357g				35
509		353g				40



Roldana de Retorno Bipartida Z25

Idler Wheels Z25

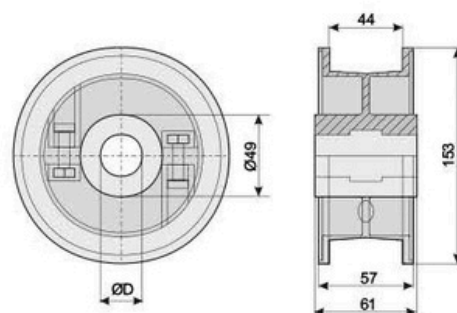

PIEZA	DESCRIP.	PESO	VENTA	COLOR	MATERIALES	Ø D
510	ROLDANA BIPARTIDA Z25	415g	Unidad	GRIS	ROLDANA=PA DISULFURO=(MO) TORNILLO=AISI 304	25
511		411g				30
512		408g				35
513		405g				40



TRACCIÓN- TRACTION

Anillo de Fijación Split Shalting Collars

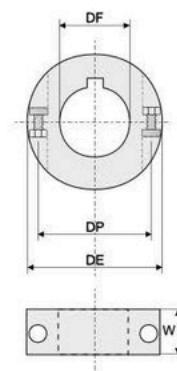
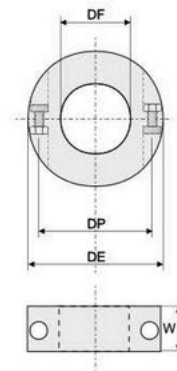

PIEZA	DESCRIP.	PESO	VENTA	COLOR	MATERIALES	Ø F	DP	DE	W
356	ANILLO DE FINACIÓN CON CHAVATERO	20g	Unidad	NEGRO	ANILLO=PAF G TORNILLO=AI SI 304	16	22	30	13
358		25g				25	34	44	14
359		29g				30	39	49	16
360		35g				35	45	54	18
361		40g				40	52	64	14
363		23g				3/4"	29	40	

PIEZA	DESCRIP.	PESO	VENTA	COLOR	MATERIALES	Ø F	DP	DE	W
1082	ANILLO DE FINACIÓN SIN CHAVATERO	20g	Unidad	NEGRO	ANILLO=PAF G TORNILLO=AI SI 304	16	22	30	13
1083		25g				25	34	44	14
1084		29g				30	39	49	16
1085		35g				35	45	54	18
1086		40g				40	52	64	14
1087		23g				3/4"	29	40	

TRACCIÓN- TRACTION

Anillo de Fijación Cuadrado Blanco
Split Shafting Collars White

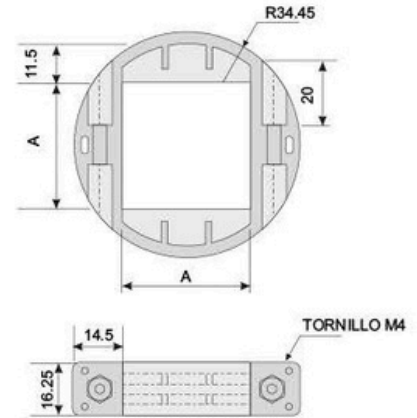

PIEZA	DESCRIP.	PESO	VENTA	COLOR	MATERIALES	A
1448 1449	ANILLO FIJACIÓN CUAD. BLANCO	40g	Unidad	NEGRO	ANILLO= PAFG TORNILLO= AISI 304	40 1 1/2"



Anillo de Fijación Cuadrado Negro
Split Shafting Collars Black

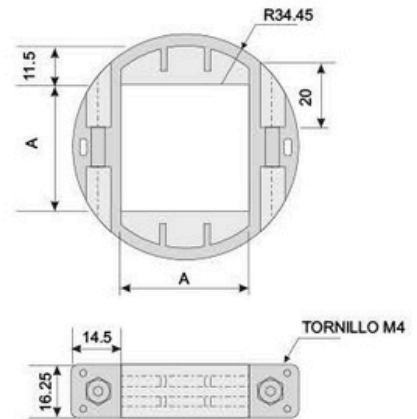

PIEZA	DESCRIP.	PESO	VENTA	COLOR	MATERIALES	A
1445 1446	ANILLO FIJACIÓN CUAD. NEGRO	40g	Unidad	NEGRO	ANILLO= PAFG TORNILLO= AISI 304 4	40 1 1/2"



TRACCIÓN- TRACTION

Rollete Retorno

Roler

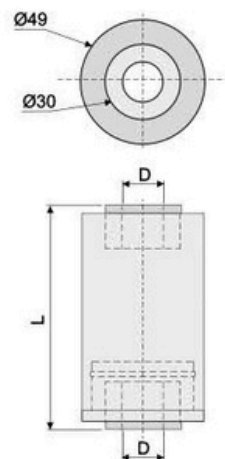

PIEZA	DESCRIP.	PESO	VENTA	MATERIALES	L	D
044	ROLLETE DE RETORNO	20g	Unidad	ROLLETE=PA	83	16,5
045		23g				19,5
321		25g				21
046		29g				16,5
047		35g				19,5
322		40g				21
048		48g				16,5
049		23g				19,5
323		29g				21

Arandela Separadora

Split Shafting Collars

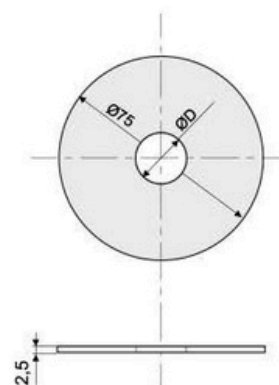

PIEZA	DESCRIP.	PESO	VENTA	MATERIALES	Ø D
038	ARANDELA SEPARADORA	10g	Unidad	ROLLETE=PA	16,5
043		9,5g			19,5
320		9g			21

TRACCIÓN- TRACTION

Puntera Rollete Retorno

Roler

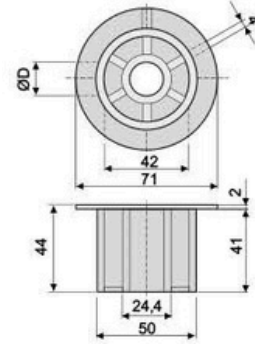

PIEZA	DESCRIP.	PESO	VENTA	MATERIALES	Ø D
145 319	PUNTERA ROLLETE	48g	Unidad	ROLLETE=PA	16,5 20

Rollete Doble

Double Roller

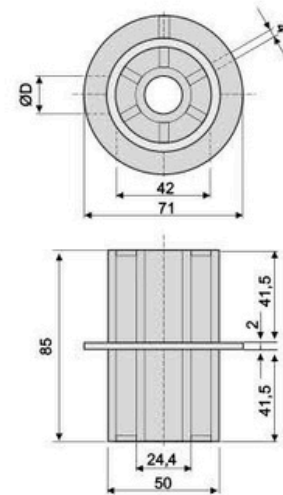

PIEZA	DESCRIP.	PESO	VENTA	MATERIALES	Ø D
144 318	ROLLETE C/ARANDELA SEPARADORA	48g	Unidad	ROLLETE=PA	16,5 20

TRACCIÓN- TRACTION

Puntera Trapezoidal de Retorno con Nervio
Sliding Shoe

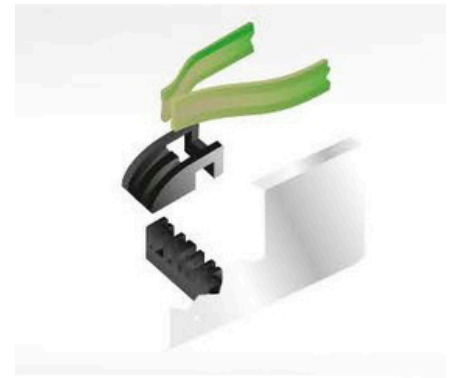

PIEZA	DESCRIP.	PESO	VENTA	COLOR	MATERIALES
999	PUNTERA DE RETORNO CON NERVIO	20g	Unidad	NEGRO	PUNTERA=PE

Puntera Trapezoidal de Reenvío
Sliding Shoes

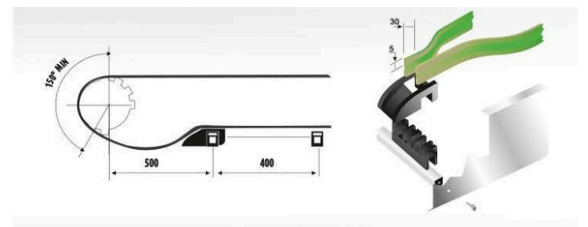
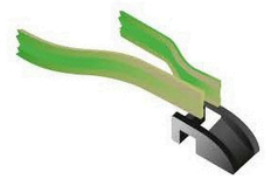
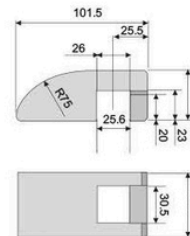

PIEZA	DESCRIP.	PESO	VENTA	COLOR	MATERIALES
948	PUNTERA TRAPEZOIDAL DE REENVÍO	20g	Unidad	NEGRO	PUNTERA=PE

TRACCIÓN- TRACTION

SopORTE Porta Perfil de Retorno 20x20

Spacer For Serpentine 20x20

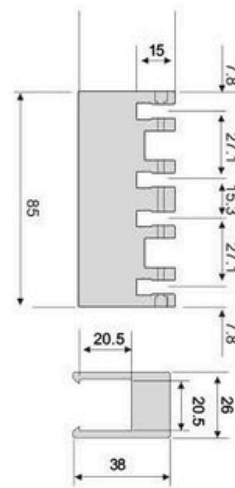

PIEZA	DESCRIP.	PESO	VENTA	COLOR	MATERIALES	ACCESORIOS
922	SOPORTE PORTA PERFIL	35g	Unidad	NEGRO	PUNTERA=PE	PIEZAS: 920 921 947

EJEMPLO DE APLICACION:

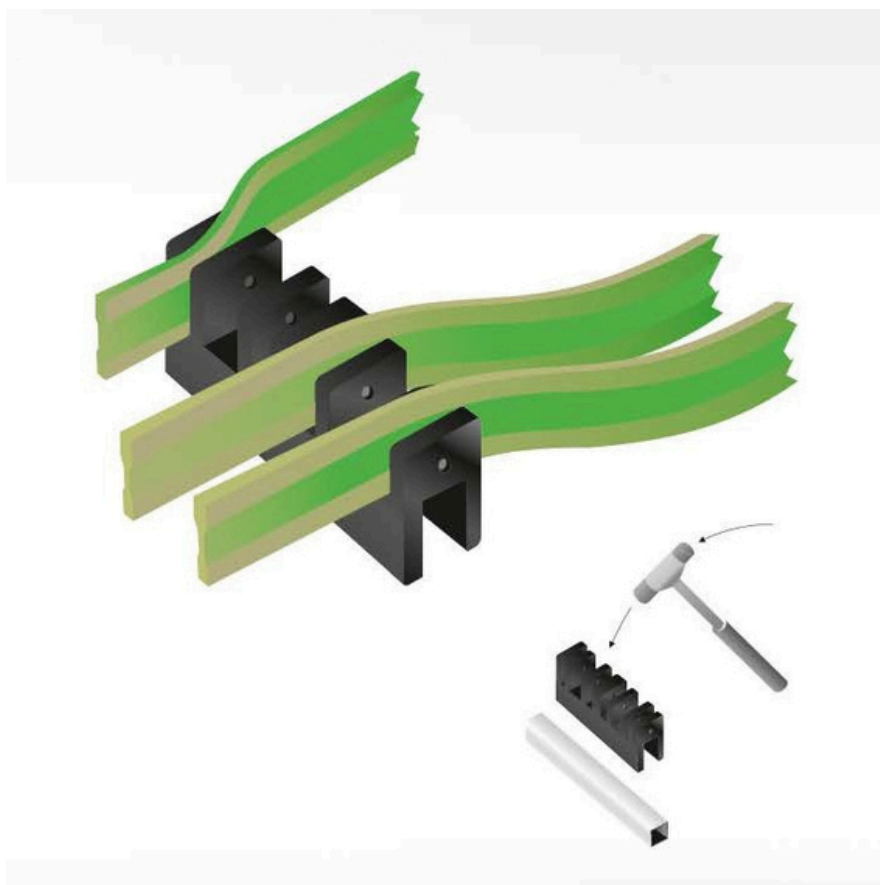

TRACCIÓN- TRACTION

Separador Trapezoidal 20x20
Puntera y Medio
 Side Spacer 20x20



PUNTERA

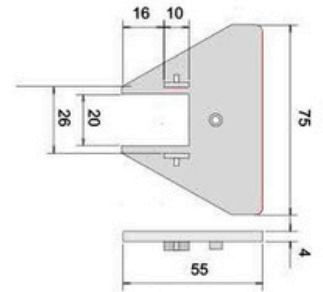

MEDIO

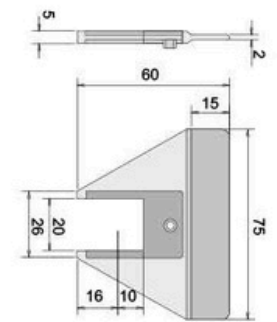

PIEZA	DESCRIP.	PESO	VENTA	COLOR	MATERIALES	ACCESORIOS
920 921	SEPARADORA PUNTERA 20X20 SEPARADOR MEDIO 20X20	15g 10g	Unidad	NEGRO	SEPARADOR=PA	PIEZAS: 130

EJEMPLO DE APLICACION:

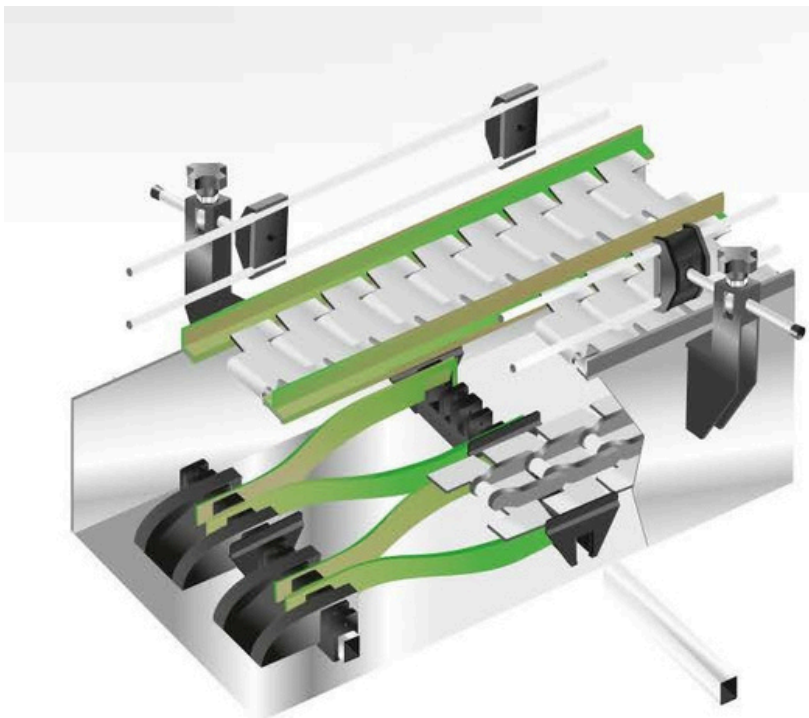

TRACCIÓN- TRACTION

Módulo de Transferencia de Entrada End Transfer Module (With Lip)

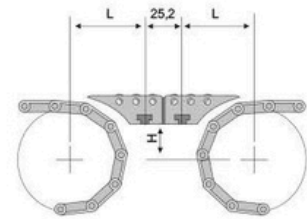
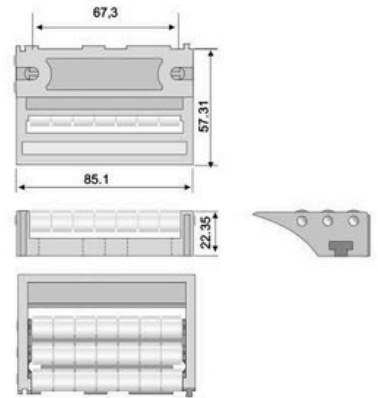

PIEZA	DESCRIP.	PESO	VENTA	COLOR	MATERIALES
1097	MÓDULO DE TRANSFERENCIA	90g	Unidad	NEGRO	CUERPO=POM RODILLOS=POM EJES=AISI 304

EJEMPLO DE APLICACION:

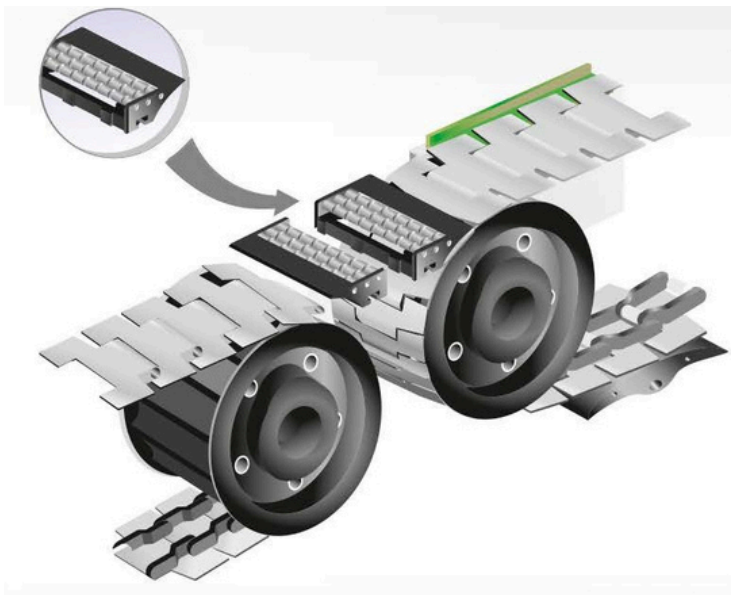

CADENA	PIÑÓN	H	L
820	Z17	36,4	66,1
	Z19	43,4	68,3
	Z21	49,4	69,4
	Z23	55,3	70,6
	Z25	61,3	71,6
801 - 805 812 - 815 881M - 8811 8811 TAB	Z17	36,8	65,8
	Z19	42,8	67
	Z21	48,7	68,1
	Z23	54,7	69,2
	Z25	60,7	70,2
821	Z17	38,8	67,1
	Z19	44,8	68,3
	Z21	50,1	69,4
	Z23	56,1	70,6
	Z25	62,1	71,6
LPB821	Z17	38,2	67,3
	Z19	44,2	68,3
	Z21	50,1	69,4
	Z23	56,1	70,6
	Z25	62,1	71,6
880 TAB - 879	Z10	46,7	67,7
	Z12	58,7	69,9
882 TAB	Z10	48,6	68,1
	Z12	60,6	70,2
LBP882	Z10	63,1	70,6
	Z12	75,1	71,5

TRACCIÓN- TRACTION

Módulo de Transferencia de Salida End Transfer Module

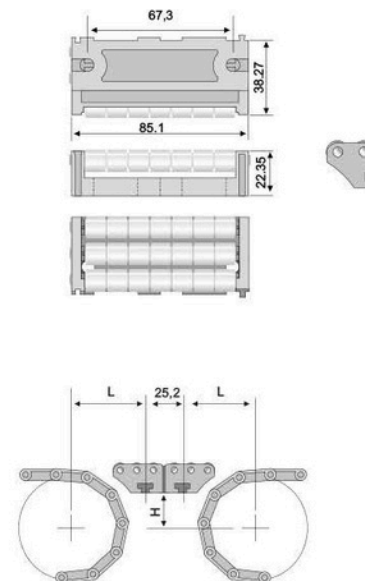

PIEZA	DESCRIP.	PESO	VENTA	COLOR	MATERIALES
1098	MÓDULO DE TRANSFERENCIA	82g	Unidad	NEGRO	CUERPO=POM RODILLOS=POM EJES=AISI 304

EJEMPLO DE APLICACION:

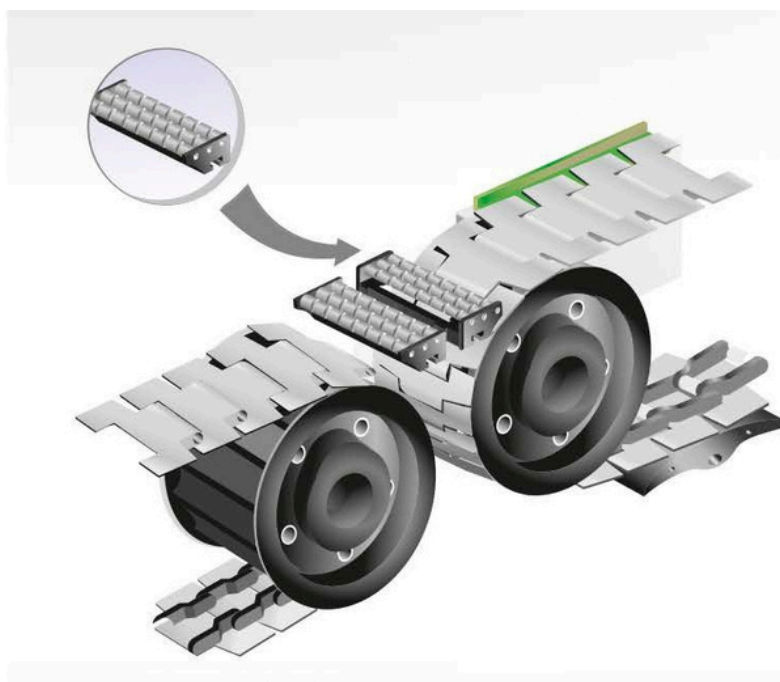

CADENA	PIÑÓN	H	L
820	Z17	36,4	66,7
	Z19	43,4	67,9
	Z21	49,3	66
	Z23	55,3	70,1
	Z25	61,3	71,2
801 - 805 812 - 815 881M - 8811 8811 TAB	Z17	36,8	65,8
	Z19	42,8	67
	Z21	48,7	68,1
	Z23	54,7	69,2
	Z25	60,7	70,2
821	Z17	38,2	67,1
	Z19	44,2	68,3
	Z21	50,1	69,4
	Z23	56,1	70,6
	Z25	62,1	71,6
LPB821	Z17	38,2	67,1
	Z19	44,2	68,3
	Z21	50,1	69,4
	Z23	56,1	70,6
	Z25	62,1	71,6
880 TAB - 879	Z10	46,7	67,7
	Z12	58,7	69,9
882 TAB	Z10	48,6	68,1
	Z12	60,6	70,2
LBP882	Z10	63,1	70,6
	Z12	75,1	72,5

TRACCIÓN- TRACTION

Módulo de Transferencia Central Centre Transfer Module

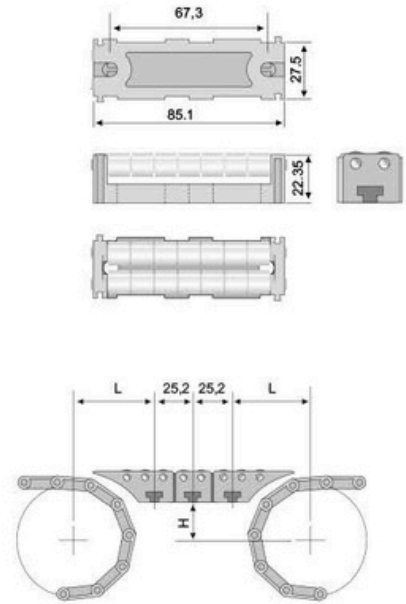

PIEZA	DESCRIP.	PESO	VENTA	COLOR	MATERIALES
1096	MÓDULO DE TRANSFERENCIA	62g	Unidad	NEGRO	CUERPO=POM RODILLOS=POM EJES=AISI 304

EJEMPLO DE APLICACION:

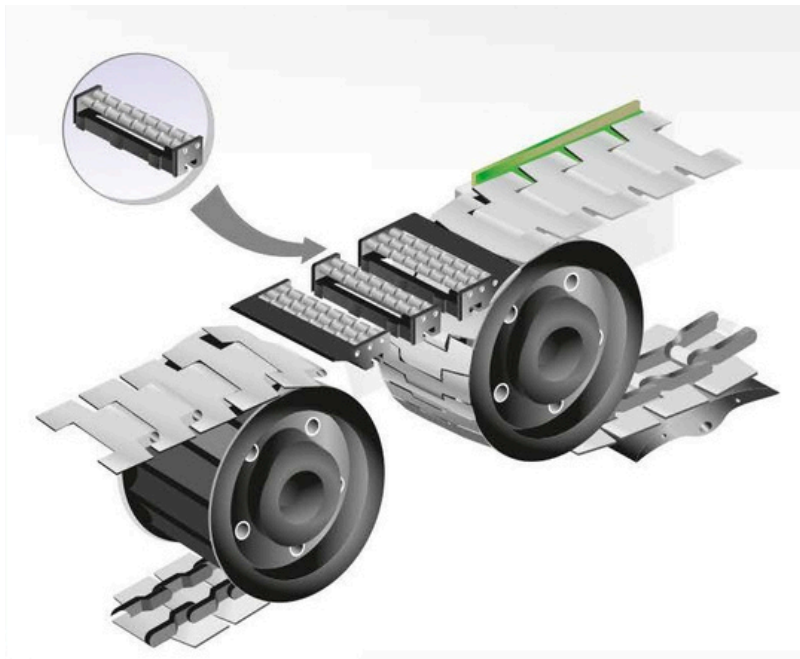

CADENA	PIÑÓN	H	L
820	Z17	36,4	66,7
	Z19	43,4	67,9
	Z21	49,3	66
	Z23	55,3	70,1
	Z25	61,3	71,2
802- 805 812 - 815 881M - 881I 881I TAB	Z17	36,8	65,8
	Z19	42,8	67
	Z21	48,7	68,1
	Z23	54,7	69,2
	Z25	60,7	70,2
821	Z17	38,2	67,1
	Z19	44,2	68,3
	Z21	50,1	69,4
	Z23	56,1	70,6
	Z25	62,1	71,6
LPB821	Z17	38,2	67,1
	Z19	44,2	68,3
	Z21	50,1	69,4
	Z23	56,1	70,6
	Z25	62,1	71,6
880 TAB - 879	Z10	46,7	67,7
	Z12	58,7	69,9
882 TAB	Z10	48,6	68,1
	Z12	60,6	70,2
LBP882	Z10	63,1	70,6
	Z12	75,1	72,5

TRACCIÓN- TRACTION

Patín de Deslizamiento (juego)

Wear Strip Shoe

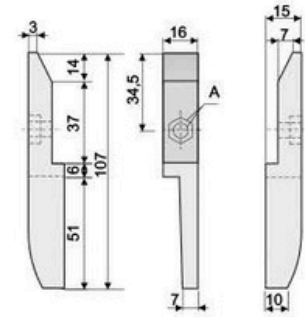

A = ALOJAMIENTO PARA
TORNILLO W1/4"

PIEZA	DESCRIP.	PESO	VENTA	COLOR	MATERIALES
052	PATÍN DE DESLIZAMIENTO	29g	Unidad	NEGRO	PATÍN= PA TORNILLO= W 1/4

Puntera Patín de Retorno

Wear Strip Shoe

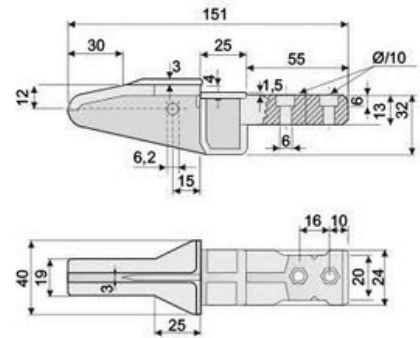

PIEZA	DESCRIP.	PESO	VENTA	COLOR	MATERIALES
367	PATÍN DE RETORNO	46g	Unidad	NEGRO	PUNTERA=PA



TRACCIÓN- TRACTION

Elemento Tensor Chico - Grande

Small Tensile Element
Big Tensile Element



Chico

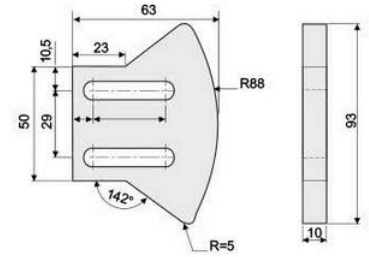

Grande

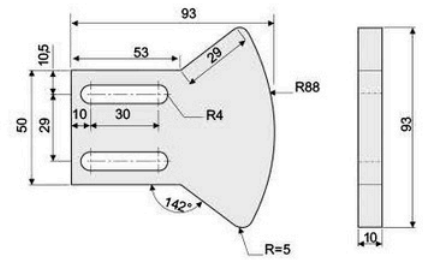

PIEZA	DESCRIP.	PESO	VENTA	MATERIALES
035 036	TENSOR CHICO TENSOR GRANDE	37,8g 53,8g	Unidad	ELEMENTO=PAFG



Elemento Tensor Media Luna

Half Moon Tensile Element

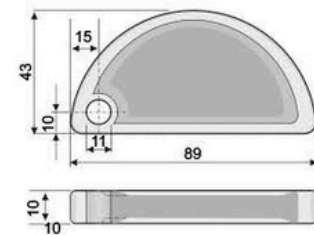

PIEZA	DESCRIP.	PESO	VENTA	MATERIALES
816	TENSOR MEDIA LUNA	27g	Unidad	ELEMENTO= PAFG

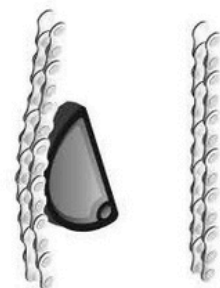



DONDE ESTAMOS

**MONTEVIDEO 561
GUAYMALLÉN (5519).
MENDOZA. ARGENTINA**

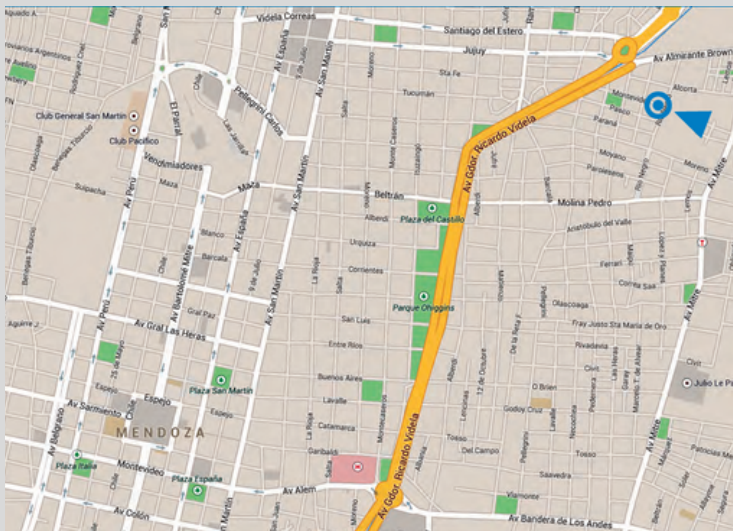

CONTÁCTANOS

+54 9 261 3878497

www.surtecnica.ar

infocomercial@surtecnica.com

[surtecnica](https://www.instagram.com/surtecnica)

